

Commercial S2 Rectangular Leg Assembly Instructions

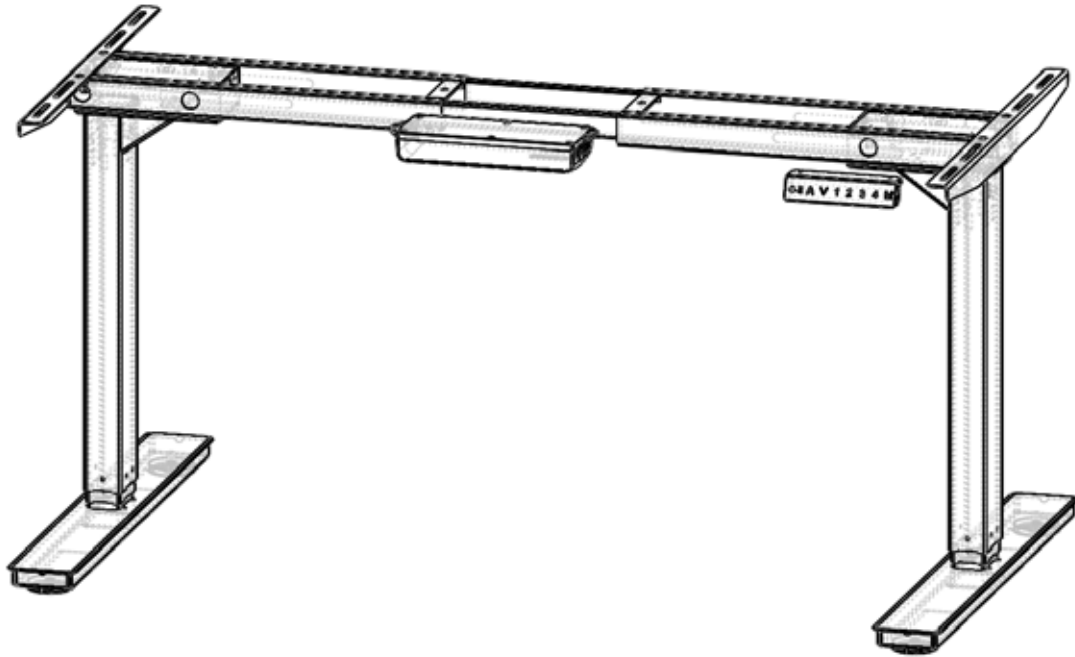

Note: Please use these Assembly Instructions and no others. Do not use the instructions that came in the frame box.

Title: Commercial S2 Rectangular Leg Assembly Instructions

Issue: 3

Issue Date: 11/05/2022

Author: SD

File Name: Commercial S2 Rectangular Leg Assembly Instructions

Issue 3 11.05.2022

To view a step-by-step assembly video, please visit:

<https://vimeo.com/432446899>.

or

Scan the code



Cautions and Use

Caution. Make sure that when operating this desk after assembly no objects are in the path of the desk when it is being raised or lowered. Failure to ensure complete assembly and to also take adequate care when using the desk could result in injury to persons and property.

Should this desk be re-sold please ensure these instructions are passed to the buyer.

In the event that any screws, allen keys or any other components or fasteners are missing from the box when opened please contact GoStand Limited at the contact details on the cover page.

Inappropriate use of this desk could cause injury to persons and property.

Do not dismantle any single parts within the product.

Please make all users of the desk aware of these important safety instructions.

The desk is not designed for a person to either sit on it or to move the desk up and down whilst sitting on the desk. This can cause bodily injury. Do not crawl around or lie under the desk while it is in use.

This height adjustable desk is for office or home office use only. It is not designed for use in any other environment. It should not be used in industrial areas, food preparation, workshops or other. It should not be in a high moisture environment nor subject to exposure to fluids.

The desk is designed to lift office equipment such as a computer, keyboard, monitor, mouse, tablet and stationery. It should not be sat on by any person and should above all not be moved up or down with a person on it. It should be free to move up and down without hindrance. Objects should not be placed below or around the desk that can be crushed or cause the desk to jam.

GoStand Limited accepts no liability for any injury or loss caused by improper assembly or use of this product. Similarly improper use of the product will void any and all warranty claims.

Children should be supervised by an adult at all times when using the desk.

Post Assembly and Positioning

Once the desk has been assembled adjust the feet so the desk is level and stable.

Make sure the desk is clear of any objects when positioning such as radiators, windows, furniture etc.

Do not place any objects greater than 500mm in height below the desk. Do not lift it by the desk top but by frame just underneath.

Use caution when manoeuvring desk.

Before starting the assembly process

Try to work in a carpeted or padded place.

Assembly is generally easiest at floor level.

If putting the desk-top on with the frame upside down we would recommend having someone on hand to turn the desk over.

Parts & Tool List

1. Frame Ends (x2)



2. Support Beams (x2)



3. Brackets (x2)



4. Left Leg Column



5. Right Leg Column



6. Feet (x2)



7. Control Box



8. Control Panel



9. Rubber Cushions (x10)



10. Foot Pads (x4)



11. 4mm Hex Spanner



12. M6*14 Screws (x16)



13. M6*10 Screws (x4)



14. M6*16 Screws (x4)



15. M6*12 Screws (x8)



16. ST3, 5*19 Screws (x2)



17. ST4, 8*19 Screws (x8)



18. Control Panel Cable
(Attached to Control Panel)

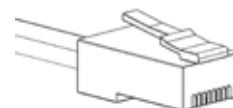

19. Power Cable

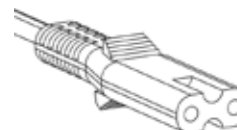

20. Leg Cables (x2)
(Attached to Leg Columns)

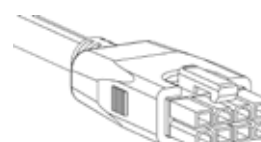

Assembly

These instructions are made simpler by running in three separate phases. We suggest you take a small break after each phase before starting the next. Always follow the phases and steps in numerical order. DO NOT JUMP AHEAD.

Phase 1: Building the basic frame of the desk

Phase 2: Attaching the desk top.

Phase 3: Connecting the motors.

PHASE 1 - We will now assemble the basic frame of the desk. This phase should take 10-15 minutes.

Step 1

Remove all parts from your desk frame box, and confirm that no items are missing. If you do have missing items please contact us immediately as we hold spares and can send out spare parts that same day.

Step 2

Now take the cross frame assembly which consists of the end frames and the support beams as we are going to separate this into separate parts.

Loosen the 4 M6*10 screws that have already been inserted into the two frame ends in the factory. Once these are loosened slide the two end frames out of the support beams so that you have two end frames and two support beams.

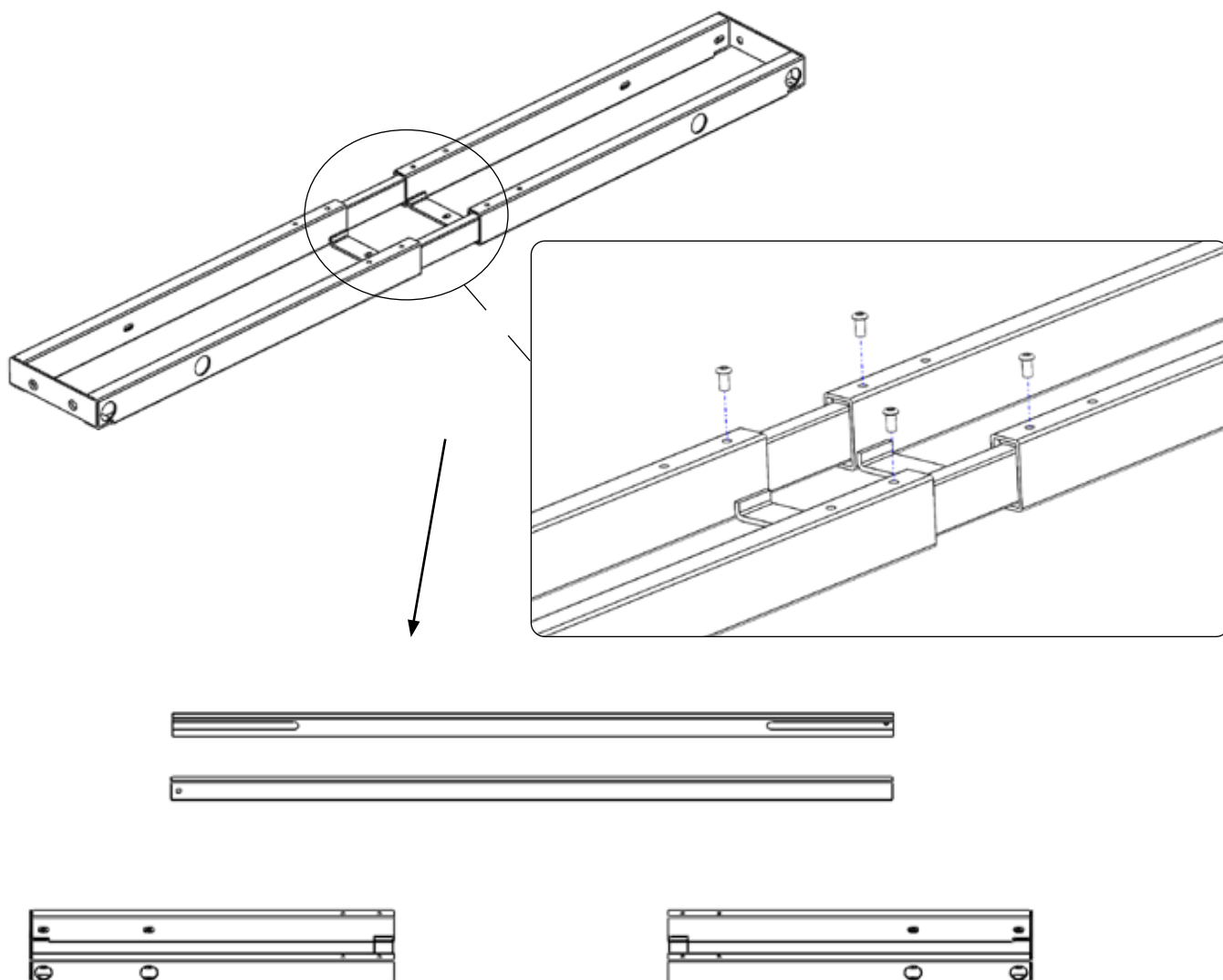

Step 3 Series 2 Dual Motor Desk Assembly

There are two assembly options for the frame depending on the date of manufacture. You can easily check if option A or option B applies to your desk. Follow the version you require.

Series 2 Desk Assembly Option A

Take either one of the frame ends and one of the leg columns.

1. Firstly insert 4 M6*14 screws through the side holes of the frame and into the leg column. Using the 4mm hex spanner.
IMPORTANT! Do not fully tighten these screws at this stage.
2. Then insert 2 M6*12 countersunk screws into the back of the leg column. Using the 4mm hex spanner. Fully tighten these screws.
3. Now tighten the 4 M6*14 screws to fully secure the frame end to leg column.

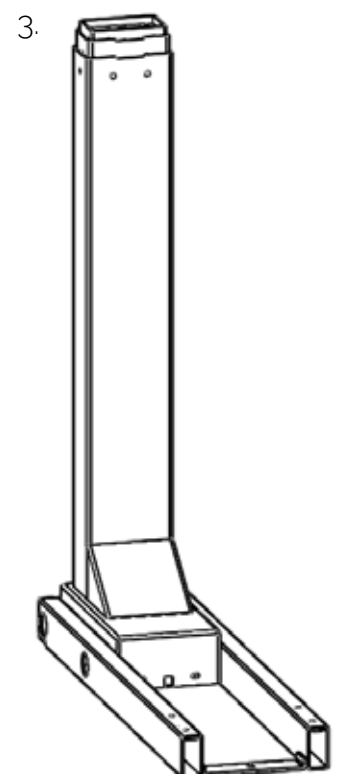
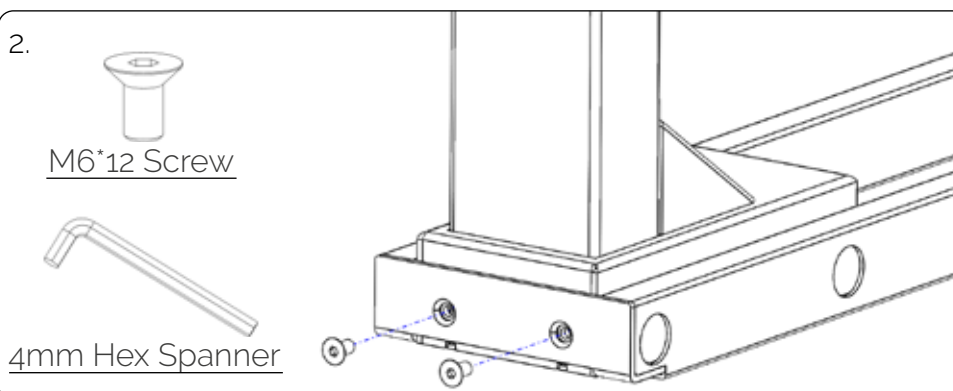
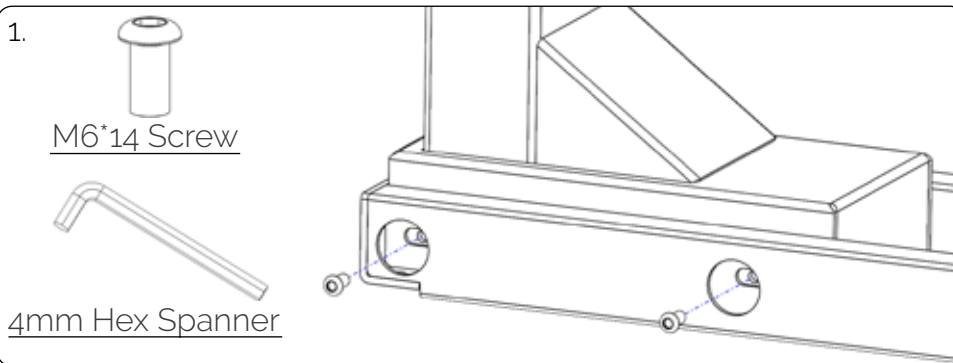

Series 2 Desk Assembly Option B

Take either one of the frame ends and one of the leg columns.

1. Firstly insert 2 M6*12 countersunk screws into the back of the leg column. Use the 4mm hex spanner.

2. Then insert 2 M6*12 countersunk screws into the front of the leg column. Use the 4mm hex spanner.

3. Now tighten the 4 M6*12 screws to fully secure the frame end to leg column.

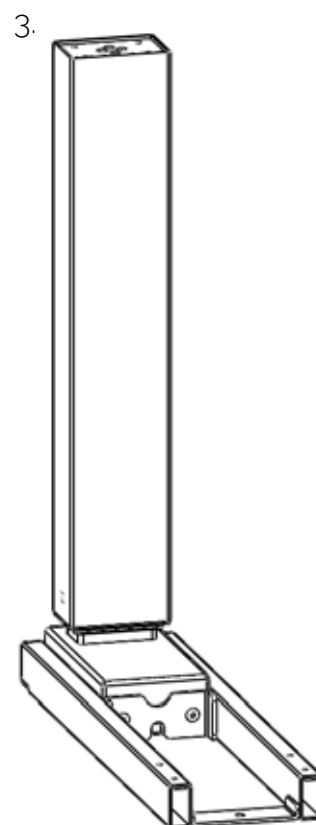
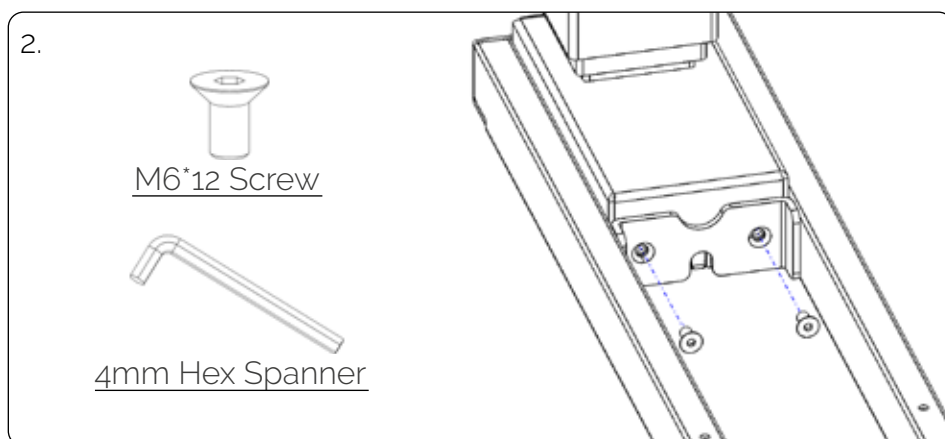
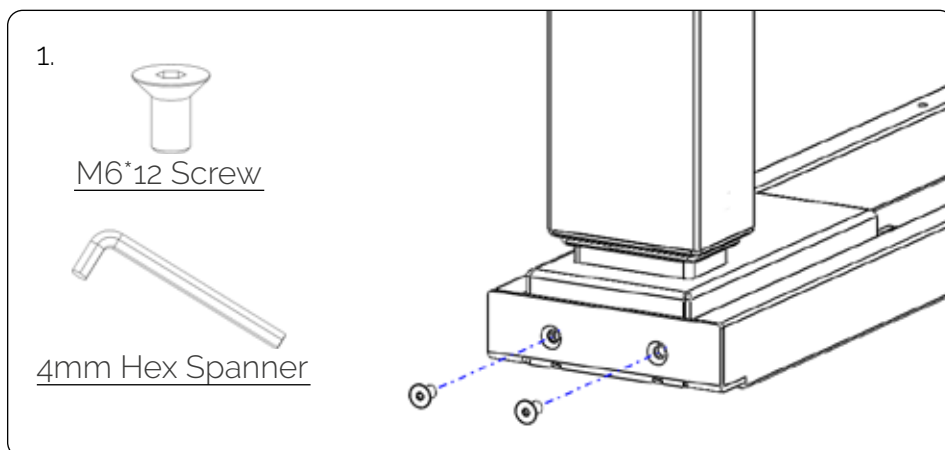

Step 4

Now we need to attach the side arm brackets.

Take either one of the side arm brackets, and secure it to the frame end with 2 M6*12 countersunk screws.

Tighten the screws using the 4mm spanner.

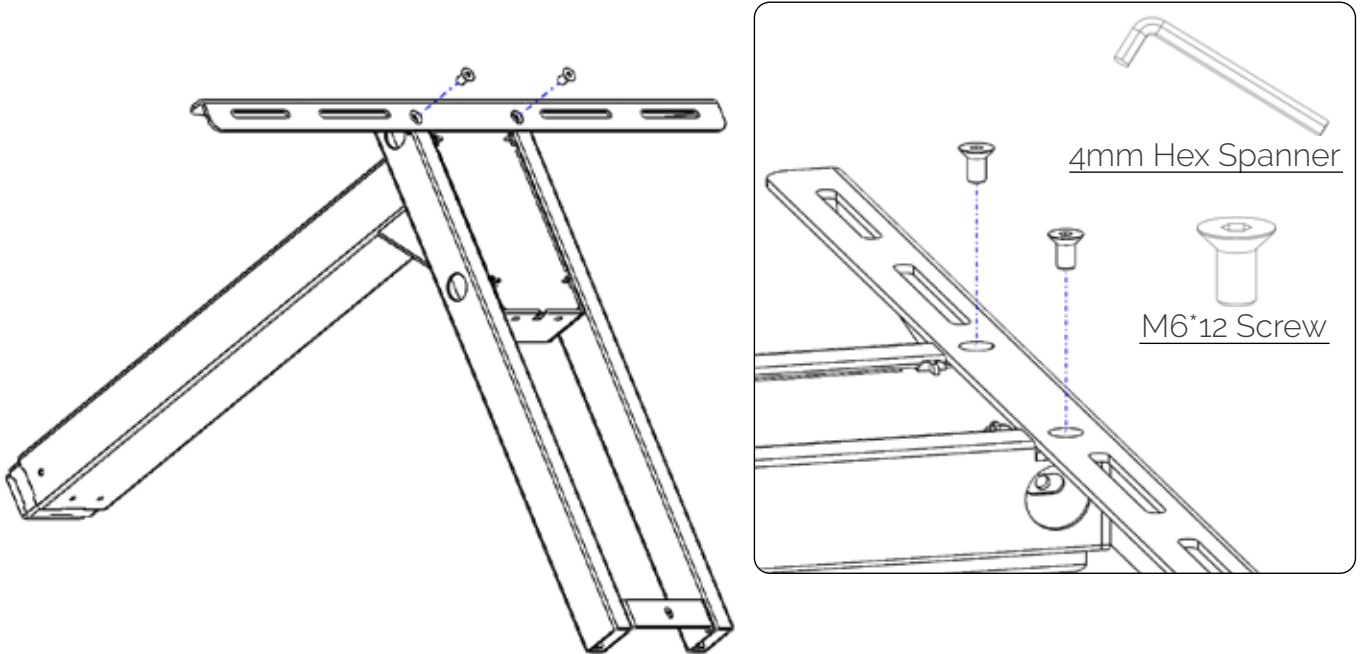

Step 5

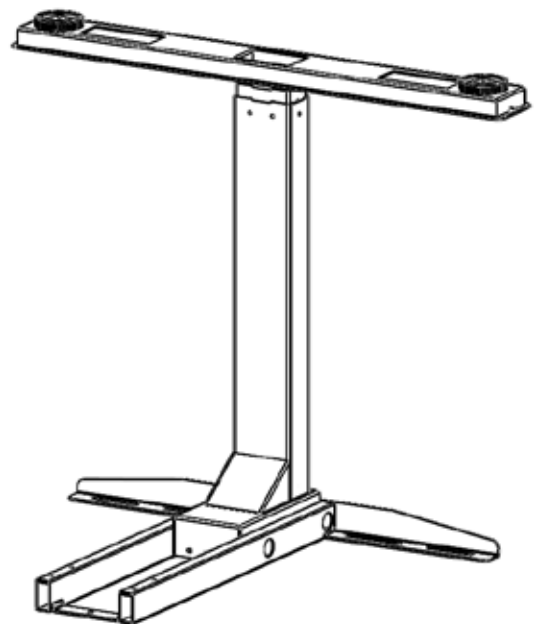
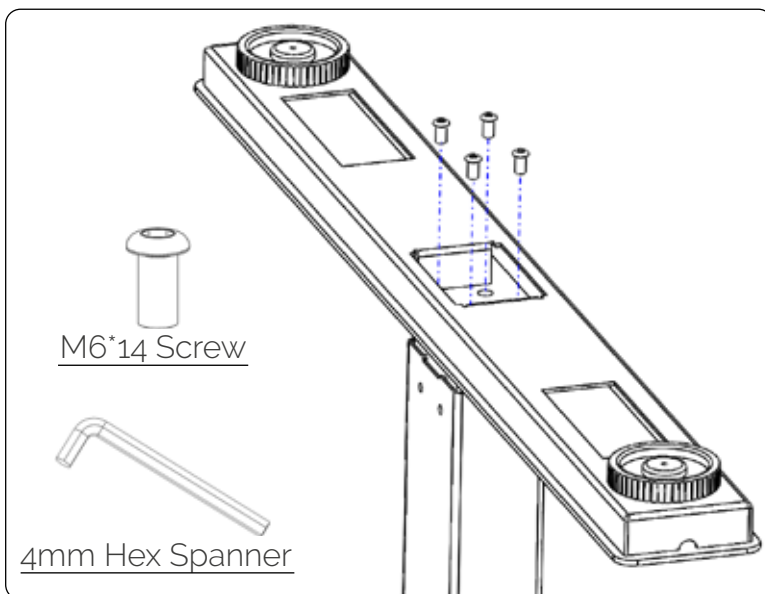

Now we need to attach the feet.

Take either foot, and secure it to the bottom of the leg column with 4 M6*14 screws.

Tighten the screws using the 4mm hex spanner.

Step 6

Repeat steps 3-5 until you have made a second identical leg sub-assembly. Once this is complete, you should have two fully built leg sub-assemblies.

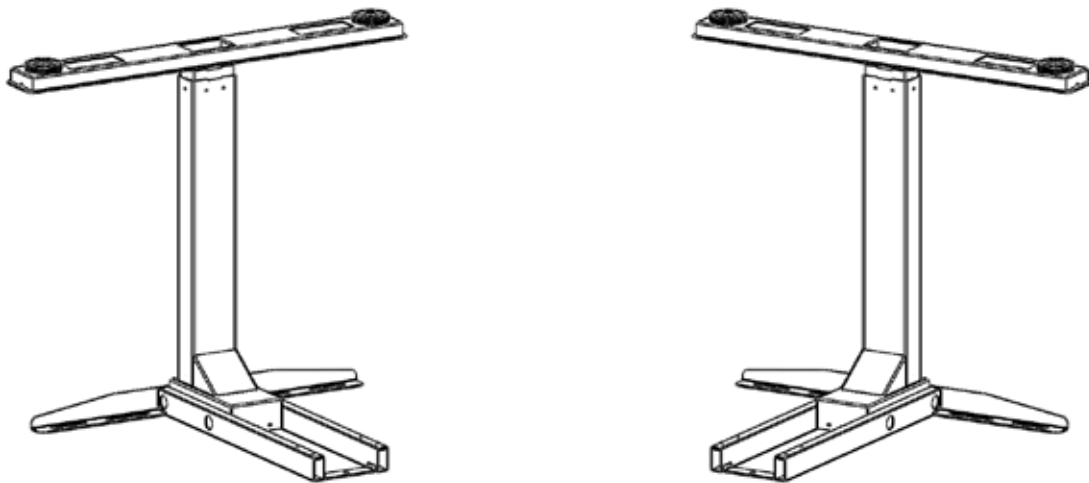

Step 7

Now you need to join the two leg sub-assemblies together so that they form the basic frame of the desk.

Place your desk-top good face down on something soft such as a carpet or rug to avoid damaging it. Place one of the leg sub-assemblies on the desk top as shown below. Insert the support beams into the frame end. Slide the second leg sub-assembly together so that they are joined by the support beams. See below.

To know which is the good face of the desk-top is simple. For inserted or pre-drilled desks, this is the blank face without the inserts or drill holes. For a blank desk-top, you can use either face unless we have added a sticker to advise which is the good face.

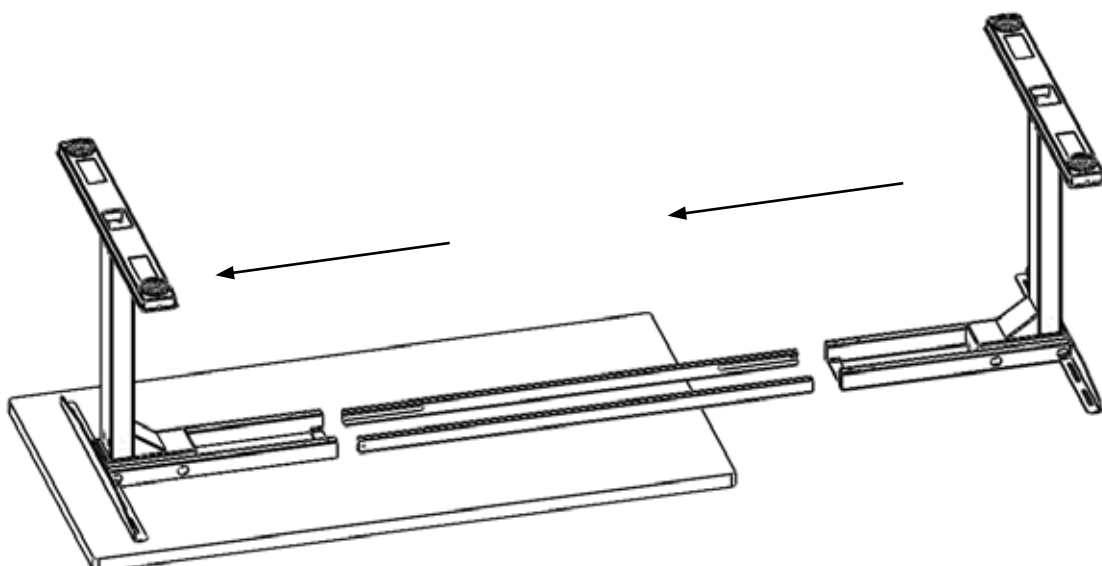

Step 7 continued

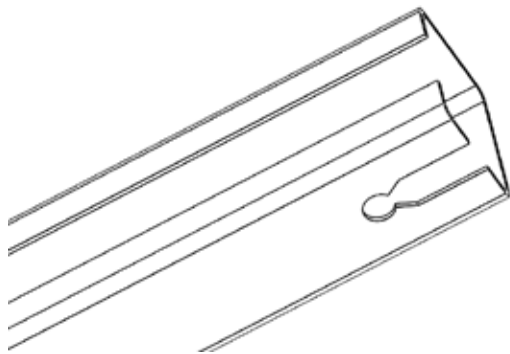

Ensure that the cut-outs in the support beams are faced downwards towards the ground, so that the beams slide easily into the frame ends and do not catch on the screws in the end sub-assemblies.

Step 8

Now we need to set the frame width to match the desk-top size that you have purchased.

Option 1 - Your desk-top is completely blank and has no holes in it at all

Measure the frame from the edge of the outside of each side arm as shown below. Use the table to decide what width to set the frame.

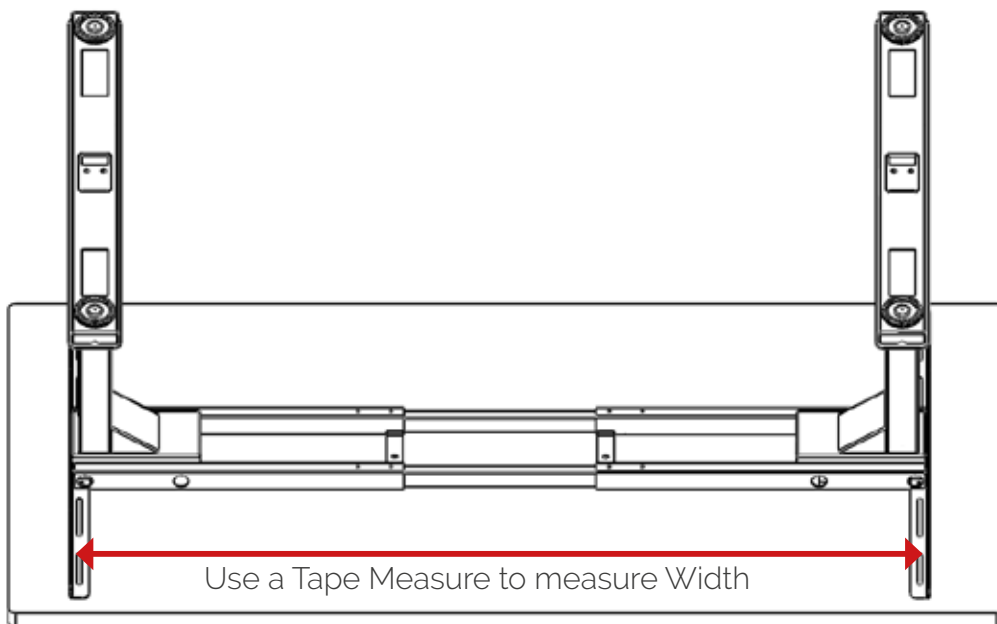

Desk Top Width	Frame Width
120 cm	110 cm
140 cm	130 cm
160 cm	150 cm
180 cm	170 cm

Note it is not necessary to measure the desk-top width just check what you ordered. Our desk tops have a tolerance of +/-10mm for manufacturing flexibility. The frame width is based on the ordered width and not the actual width.

Step 8 continued

Option 2- Your Desk-top has been pre-drilled by Gostand or has metal inserts put in by Gostand

The frame is set to the correct width by adjusting it so that the slots and holes in the frame line up with your pre-drilled holes or inserts in the desk-top (note you may need to remove the pre-fitted screws in the inserts to do this easily).

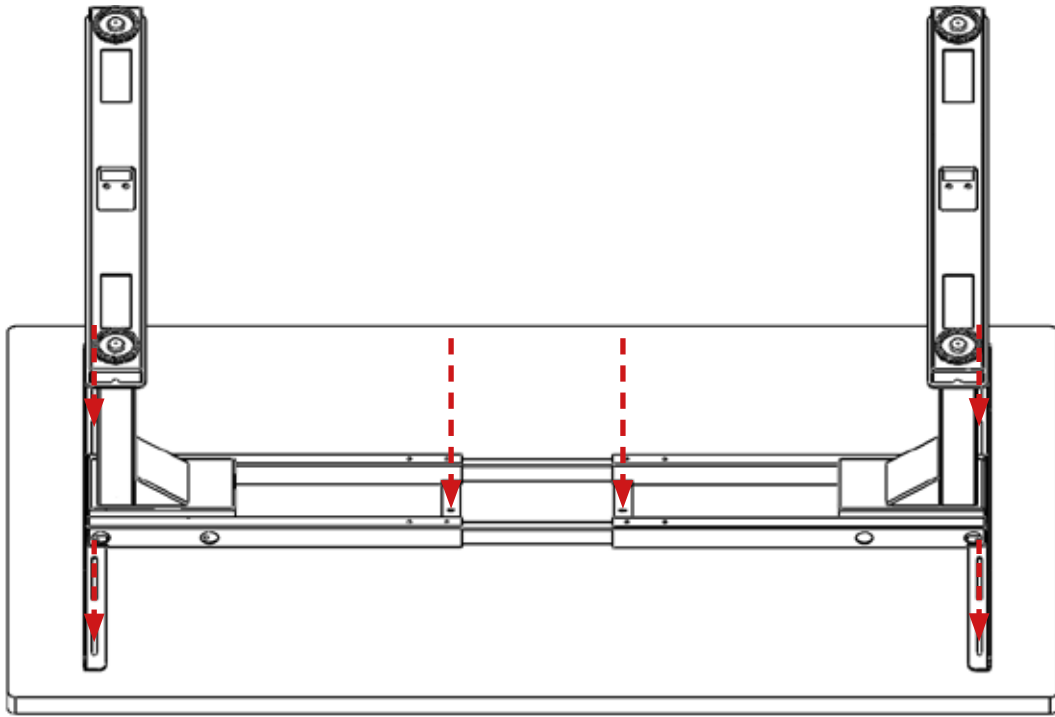

IMPORTANT! Do not tighten the M6*10 screws on the support beams at this stage, as this may make it more difficult to align your frame with the inserts or drill locations.

If the screws are tight and the support beams are rigid whilst you are manoeuvring the frame, this can lead to the frame becoming damaged.

Congratulations. You have now completed Phase 1 of the assembly and can now move onto Phase 2.

PHASE 2 - We will now attach the desk-top to the frame and control box. This phase should take 20-25 minutes.

Step 9

Now that we have achieved the appropriate width of the frame, we can now proceed to attaching the desk-top and adding the control box and control panel.

If your desk-top is blank or with pre-drilled holes please follow Step 9(a).

If your desktop has pre-installed inserts please follow Step 9(b).

Step 9(a)

Fitting a blank or pre-drilled desk-top.

Place the rubber cushions onto the brackets and beam where the screws will be inserted.

The rubber cushions provide a barrier between the desk-top and frame.

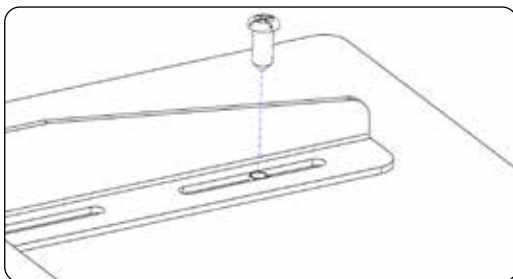
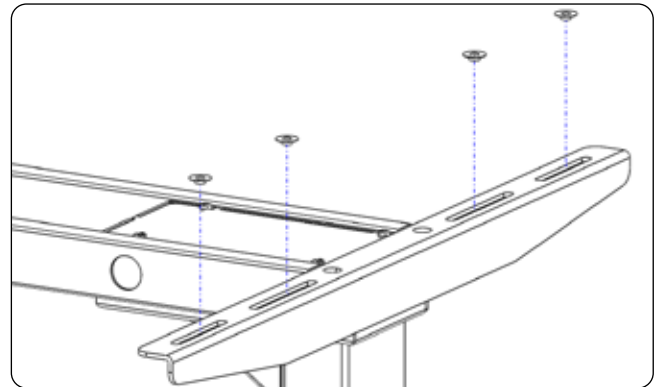

Now overturn the frame again and place it on top of the desk-top. Place the screws through the rubber cushions, and then proceed to drill them into the desktop.

Fit the frame to the desk-top with 6 ST4, 8*19 self-tapping screws, as shown below:

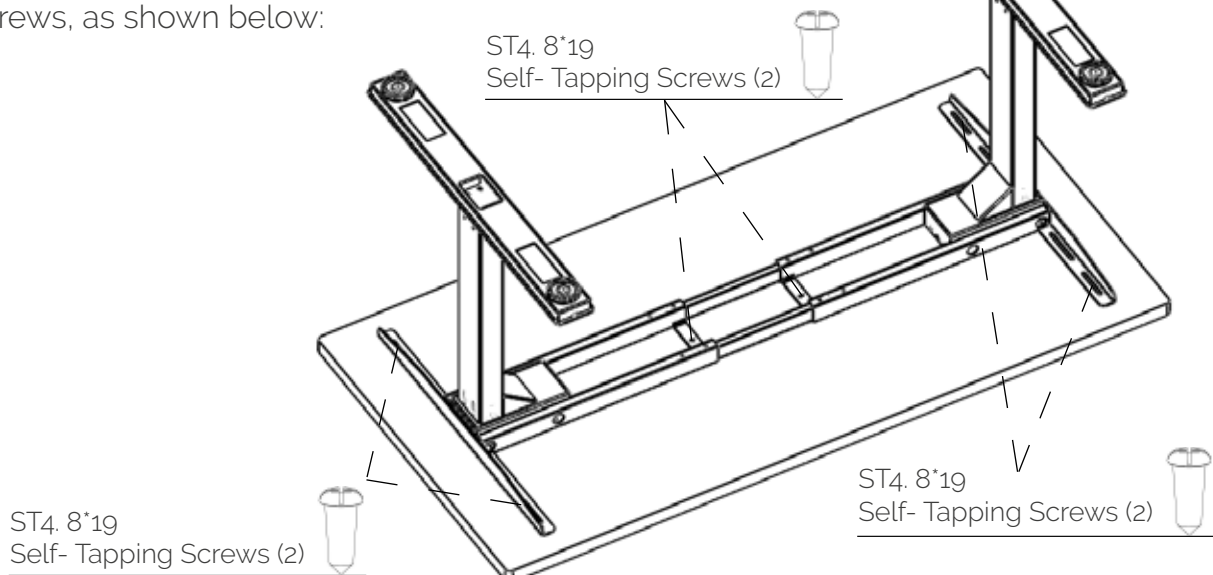

Step 9(a) continued

If your desk-top has pre-drilled holes, this means that holes have been drilled into your desk-top to indicate where the screws should be inserted into the desk-top. Align the holes of the frame, control box and control panel with the pre-drilled holes and proceed to screw the self-tapping screws into the desk-top to secure the frame to the desk-top.

Attach the control box using 2 ST4. 8*19 self-tapping screws.

The control box should be attached to the desk-top whilst being held in the in between the support beams. This will allow the desk to be built in the most compact way possible.

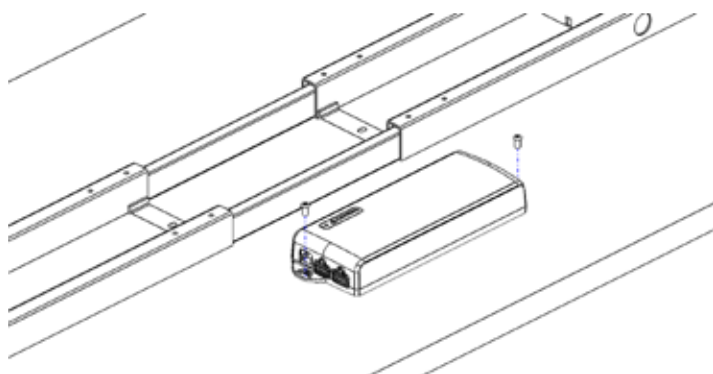
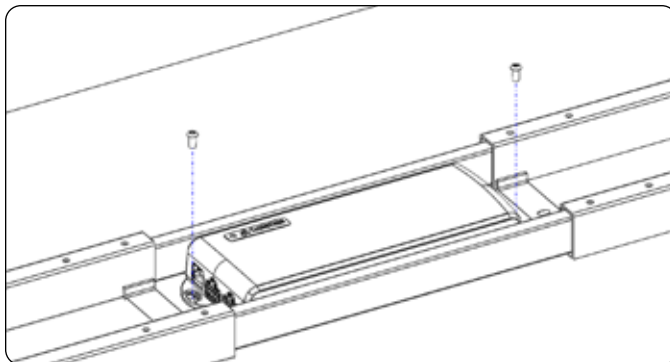

Attach the control panel using 2 ST3. 5*19 self-tapping screws.

If you have a blank desk-top, this can be placed wherever you prefer. We advise you place the control panel at the edge of the desk-top to allow the buttons to be easily accessible.

However, if the leg sub-assemblies are close together, the control box may not fit in between the support beams.

In this case, the control box can be attached to the desk-top whilst placed outside of the support beams.

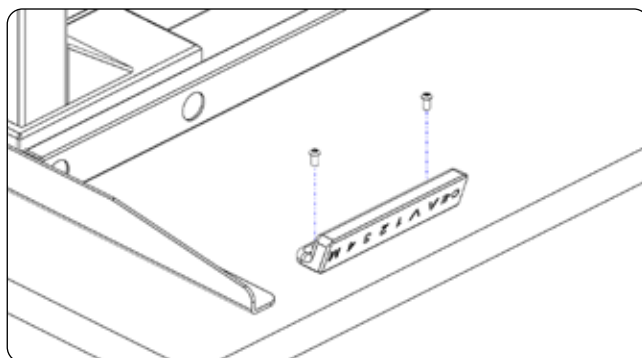

Once the desk-top is attached, tighten the the M6*10 screws you loosened in Step 2. Also place 4 more in the empty holes of the frame ends and tighten these well so the frame is rigid.

Step 9(b)

Fitting a pre-inserted desk-top.

If your desk-top has inserts in place, this means at the factory we have installed metal components into the desk-top which allow the frame to be secured to the desk-top with engineering hex headed screws and not wood/self-tapping screws.

The screws referred to in this section are not in the screw pack but will be in the inserts when the desk is delivered. You will need to remove them to complete the next sections.

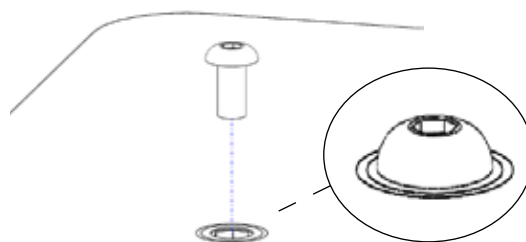

Step 9(b) continued

First the frame is positioned by aligning the frame with the inserts (see Step 8, *Option 2*). The frame can be attached to the desk-top by screwing 4 off M6*14 into the bracket inserts and 2 off M5*14 screws into the crossframe inserts.

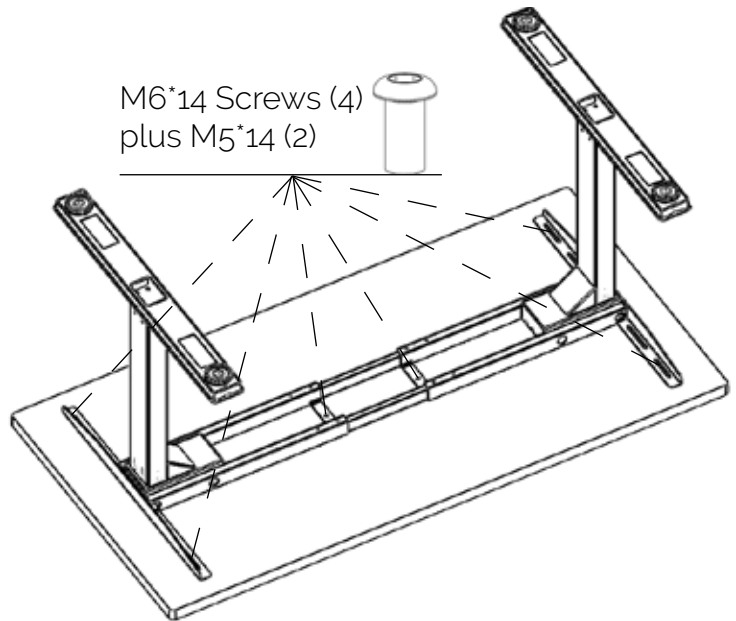
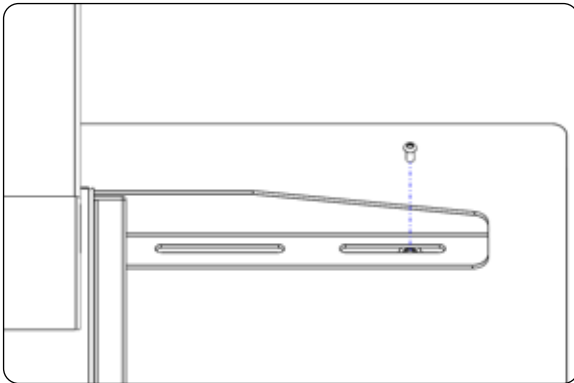

The control box and control panel can now be attached to the desk-top.

The control box is attached to the desktop by screwing 2 off M5*16 screws into it's specific inserts.

The control box should be placed in between the support beams. This will allow the desk to be built in the most compact way possible.

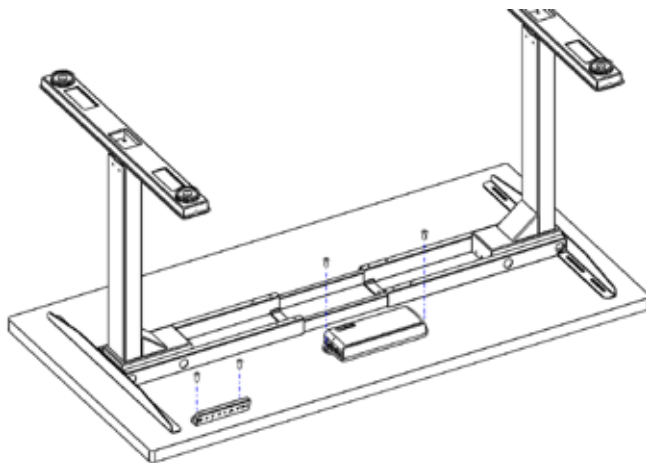
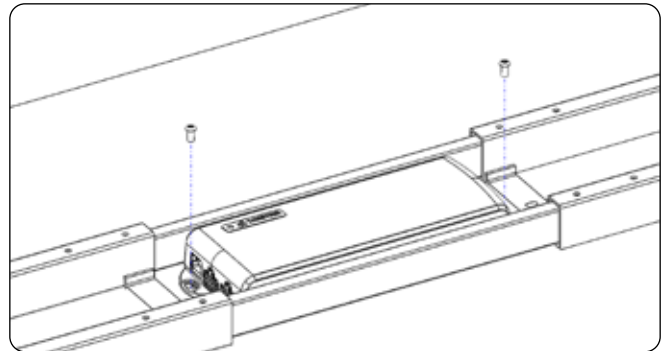

If the leg sub-assemblies are close together, the control box may not fit in between the support beams.

In this case, the control box can be attached to the desk-top whilst placed outside of the support beams.

Similarly, the control panel is attached to the edge of the desk-top by screwing 2 off M4*16 screws into it's specific inserts at the edge of the desk-top.

Once the desk-top is attached, tighten the the M6*10 screws you loosened in Step 2. Also place 4 more in the empty holes of the frame ends and tighten these well so the frame is rigid.

Congratulations. You have now completed Phase 2 of the assembly and can now move onto Phase 3.

PHASE 3 - We are going to connect the motor. This phase should take 5 - 10 minutes.

Step 10

To ensure that your desk's height can be adjustable, the control box must be correctly connected to the leg modules, control panel and power supply.

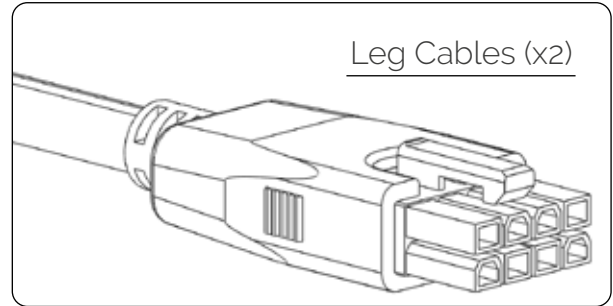
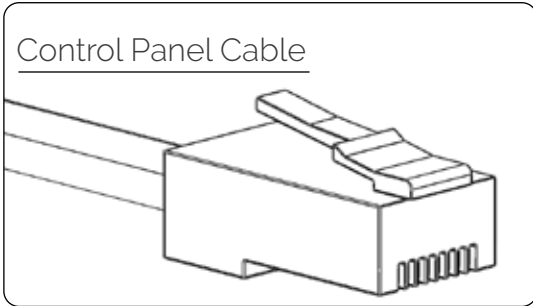

Note that the Control Panel Cable is already attached to the control panel and the Leg Cables are already attached to the legs.

Connect the control panel to the control box by plugging the loose end of the control panel's cable into the suitably shaped port. As shown.

Connect the two legs to the control box by plugging the two loose ends of the leg cables into the suitably shaped ports. As shown.

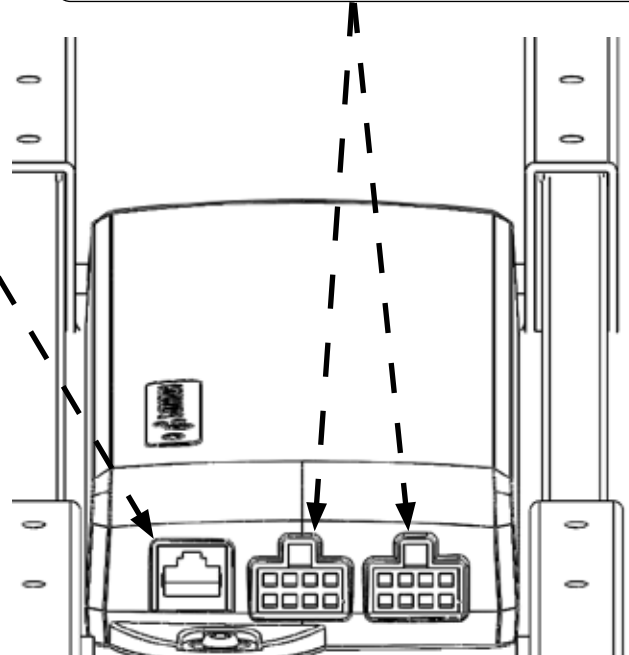

Now, on the other side of the control box, connect the power cable to the control box. This is done by plugging the power cable into the suitably shaped port. As shown.

Then, plug the other end of the power cable into a mains plug socket.

This will provide power to the desk's raising system.

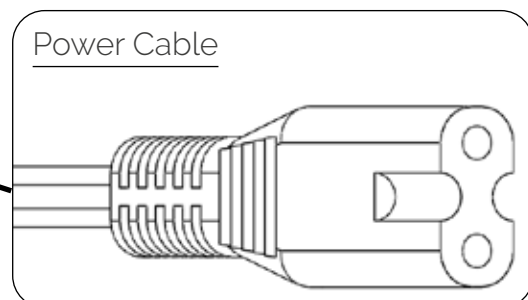
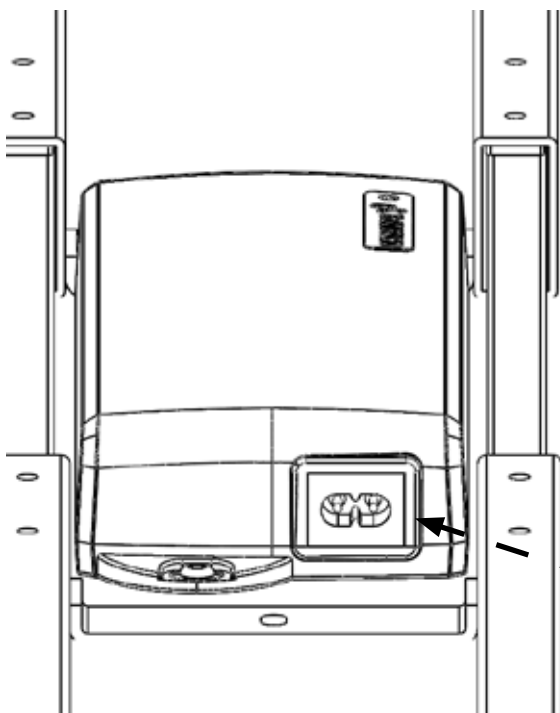

Step 11

Setting up the desk's lifting system.

1. The set-up of your desk's lifting system must be done after the desk is built and before you begin using the desk. If you attempt to test the system with the control box loose you will find the anti-collision system kicking in and an error being shown. The control box and handset must be rigidly fixed to avoid this eventuality.
2. You must initialise/reset the desk before use.

Series 2 Dual Motor Control Panel set-up

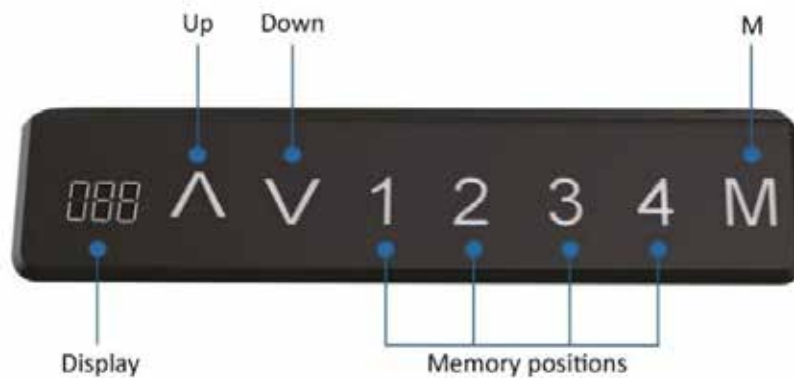

Initialization of the system (reset):

1. Press and hold the "Up" and "Down" arrows until the frame has reached it's lowest position;
2. A 'beep' will sound to indicate to you that initalization is complete. Your lifting system will then be fully operational.

Setting the memory function:

1. Place the desk up or down to the desired position;
2. Press "M" until the display flashes, then press "1" to save position 1;
3. Repeat the procedure to save the other positions. (4 memory positions in total).

CM or INCH settings:

1. Press "1", "2" & "M" together for 5 seconds;
2. Then "CI" will flash on the display;
3. Press "1" for CM or press "2" for INCH.

Series 2 Dual Motor Control Panel set-up Continued

Setting the minimum height of the desk:

This sets a height below which the desk will not go in normal operation. It is important to check it is set properly before placing objects below the desk. Gostand does not recommend placing objects below a desk that are greater in height than the desk absolute minimum height of approx 60cm.

1. Place the desk at the desired minimum height
2. Press the "Up" arrow and "Down" arrow simultaneously for 1 second before releasing the "Up" arrow and continuing to hold the "Down" arrow. Now while continuing to hold the "Down" arrow press the "Up" arrow three times.
3. A beep will be heard signifying the minimum height has been set.

If "E00" shows during step 2 you have held the "Up" and "Down" button for too long and gone into reset mode. You will have to finish the reset and then re-start the procedure again from the beginning.

To remove this minimum height setting the desk must be moved to the minimum height previously set above. This is normally done by holding the down key until the desk will go no lower. Now carry out steps 1-3. Again at the end of step three a beep will be heard signifying that the minimum height has been removed.

Setting the maximum height of the desk:

This sets a height above which the desk will not go in normal operation. It is important to check it is set properly if there will be a height restriction above the desk.

1. Place the desk at the desired maximum height
2. Press the "Up" arrow and "Down" arrow simultaneously for 1 second before releasing the "Down" arrow and continuing to hold the "Up" arrow. Now while continuing to hold the "Up" arrow press the "Down" arrow three times.
3. A beep will be heard signifying the minimum height has been set.

If "E00" shows during step 2 you have held the "Up" and "Down" button for too long and gone into reset mode. You will have to finish the reset and then re-start the procedure again from the beginning.

To remove this maximum height setting the desk must be moved to the maximum height previously set above. This is normally done by holding the up key until the desk will go no higher. Now carry out steps 1-3. Again at the end of step three a beep will be heard signifying that the maximum height has been removed.

Step 11 Continued

Test the ability of your frame by operating the buttons on the control panel.

Pressing the "Up" arrow will raise the frame.

Pressing the "Down" arrow will lower the frame.

Ensure that these actions occur when the buttons have been pressed. If the frame fails to adjust it's height after the buttons have been operated, then please return to Step 10 and ensure you have followed the control box connection instructions correctly.

Additional information on your control panel is available in your Control Panel User Manual.

Congratulations. You have now completed Phase 3 of the assembly.

This completes the construction of your Dual Motor sit-stand desk.

Please do not dispose of this assembly instructions document.

If you have any questions, need any spares or require assembly assistance please contact us.



UK:

Email: info@gostand.co.uk

Tel: 0800 368 9668

Ireland:

Email: Info@gostand.ie

Tel: 04890767076